

## 100G QSFP28 10km LR4 Receiver Specification

### HTQ28-4C04-10BD

#### **Feature**

- ◆ Supports 103.1Gbps aggregate bit rate
- ◆ 4x25Gbps electrical interface
- ◆ 4X25Gbps PIN/TIA receiver
- ◆ Maximum link length of 10km on Single Mode Fiber
- ◆ Hot pluggable QSFP28 footprint
- ◆ Single 3.3V power supply
- ◆ Maximum power dissipation<1.5W
- ◆ RoHS-6 compliant and lead-free
- ◆ I2C management interface
- ◆ DDM function implemented
- ◆ 0°C to +70°C case operating temperature

#### **Applications**

- ◆ 100G LR4 Ethernet links
- ◆ Other high speed data connections

#### **Standards**

- ◆ QSFP28 MSA
- ◆ IEEE802.3ba 100GBASE-LR4
- ◆ ROHS

#### **Description**

The Hirundo' s HTQ28-4C04-10BD QSFP28 transceiver modules are designed for 100Gigabit Ethernet over 10km single mode fiber. They are compliant with the 100GBASE-LR4 and IEEE 802.3ba. Mechanical dimensions, connectors and the footprint of this product is QSFP28 specifications compliant.

## 1. Ordering Information

Table 1.1 Ordering Information

Part No.	Specifications							
	Package	Date rate (Gbps)	Wavelength (nm)	Optical Power (dBm)	Sensitivity OMA(dBm)	Temp (°C)	Reach (km)	Connector
HTQ28-4C04-10BD	QSFP28	4*25.78	NC	NC	<-8.6	0~70	10	LC
<b>PN</b>	HTQ28-4C04-10BD							
<b>Description</b>	4X25Gbps,SMF, 10Km, 0-70°C							
<b>SAP No</b>	-							
<b>Customer PN</b>	-							

## 2. Revision History

Table 2.1 Revision History

Version	Initiated	Reviewed	Revision	Date
V1.0	Leo	Virgil	LiuSJ	2020.12.24

## 3. Absolute Maximum Ratings and Recommended Operating Conditions

Table 3.1 Absolute Maximum Ratings

Parameter	Symbol	Unit	Min	Max
Storage Temperature Range	Ts	°C	-40	+85
Relative Humidity	RH	%	5	85
Power Supply Voltage	Vcc	V	-0.5	+4.0
Signal Input Voltage		V	-0.3	Vcc+0.3
Receiver Damage Threshold		dBm	+3.4	

Table 3.2 Recommended Operating Conditions

Parameter	Symbol	Unit	Min	Typ	Max
Operating Case Temperature	Tc	°C	0	/	70
Power Supply Voltage	Vcc	V	3.135	3.3	3.465
Bit Rate(Per channel)	BR	GB/S		25.78	
Bit Error Ratio	BER				10 <sup>-12</sup>
Max Supported Link Length	L	Km			10

## 4. Optical Specification

**Table 4.1 Optical Specifications**

Parameter	Symbol	Unit	Min	Typ	Max	Notes
Signaling rate per lane		GBd		25.7812± 100pm		
Center wavelength	$\lambda_{IN}$	nm	1294.53 1299.02 1303.54 1308.09	1295.56 1300.05 1304.58 1309.14	1296.59 1301.09 1305.63 1310.19	
Damage Threshold Per Lane	DT	dBm			3.4	
Average receive Power per Lane	RXPx	dBm	-10.6		4.5	BER=10 <sup>-12</sup>
Receiver Sensitivity (OMA) per Lane	Rxsens	dBm			-8.6	BER=10 <sup>-12</sup>
Receiver reflectance	Rfl	dB			-26	
LOS De-Assert	LOSD	dBm			-11.6	
LOS Assert	LOSA	dBm	-24		-13.6	
LOS Hysteresis		dB	0.5		6	

## 5. Electrical Specification

**Table 5.1 Electrical Specifications**

Parameter	Symbol	Unit	Min	Typ	Max	Notes
Supply Voltage	VCC	V	3.135	3.3	3.465	
Supply Current	ICC	A			0.45	
Power Consumption	Pc	W			1.5	
<b>Receiver</b>						
Signaling rate per lane		GBd		25.7812± 100pm		
Output Differential Impedance	R <sub>OUT</sub>	$\Omega$	90	100	110	
Differential data output swing	V <sub>OUT</sub>	mVp-p	300		800	
Eye width	UI	0.57				
<b>IIC communication</b>						
IIC Clock frequency	-	KHZ	100		400	

## 6. Module Memory Map

The common memory map for managed external cable interfaces is utilized for serial ID, digital monitoring and control functions. The map is arranged into a single lower page address space of 128 bytes and multiple upper address pages.

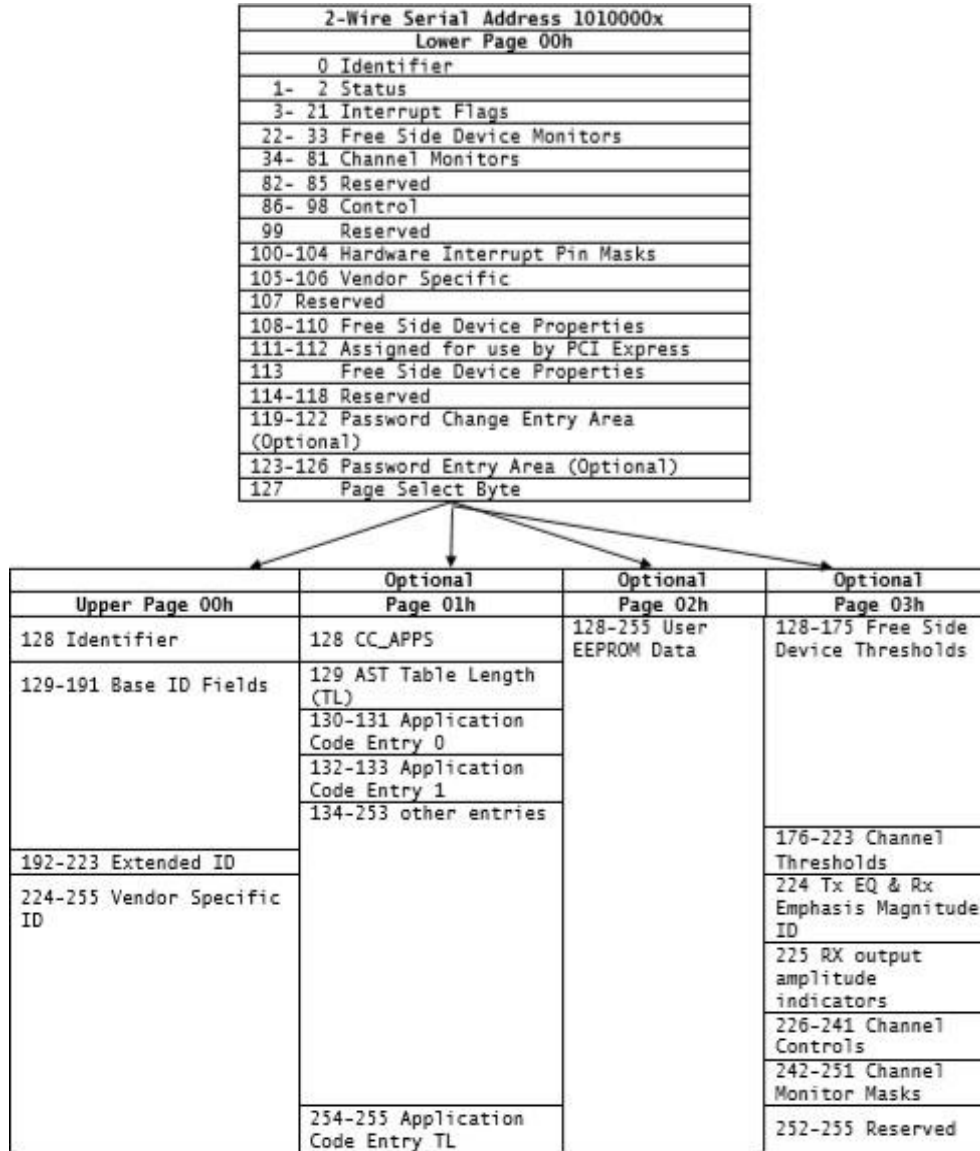

Figure 1 Digital Diagnostic Memory Map

## 7. Pin Assignment and Pin Description

### 7.1 Pin Assignment

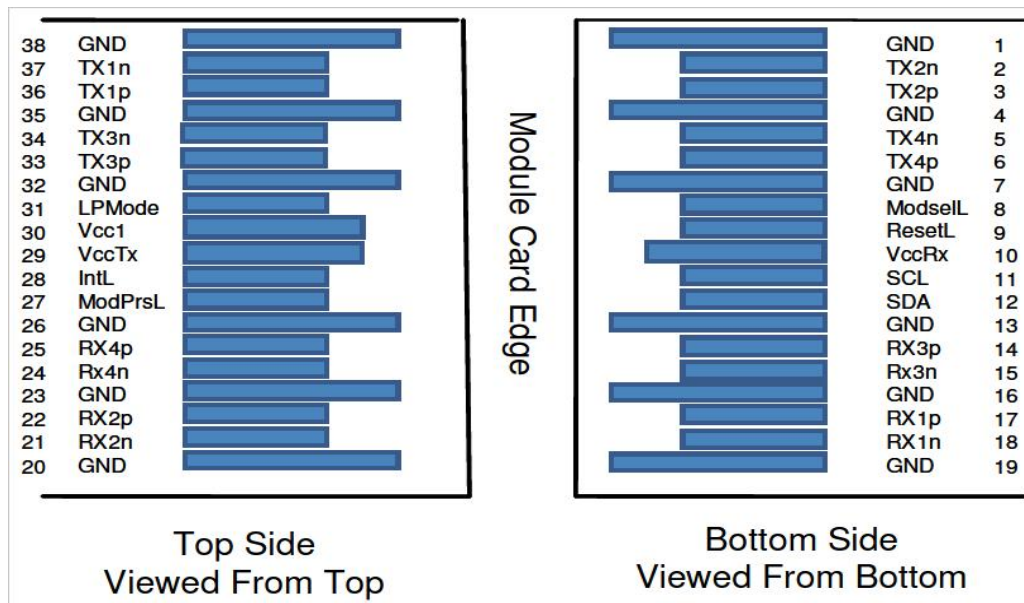

Figure 2 Electrical Pin-out Details

### 7.2 Pin Description

Table 7.1 Pin Description

Pin	Symbol	Name/Description	Note
1	GND	Ground	1
2	Tx2n	Transmitter Inverted Data Input	
3	Tx2p	Transmitter Non-Inverted Data Input	
4	GND	Ground	1
5	Tx4n	Transmitter Inverted Data Input	
6	Tx4p	Transmitter Non-Inverted Data Input	
7	GND	Ground	1
8	ModSe1L	Module Select	
9	ResetL	Module Reset	
10	Vcc Rx	+3.3V Power supply receiver	
11	SCL	2-wire serial interface clock	
12	SDA	2-wire serial interface data	
13	GND	Ground	1
14	Rx3p	Receiver Non-Inverted Data Output	
15	Rx3n	Receiver Inverted Data Output	
16	GND	Ground	1
17	Rx1p	Receiver Non-Inverted Data Output	
18	Rx1n	Receiver Inverted Data Output	
19	GND	Ground	1
20	GND	Ground	1
21	Rx2n	Receiver Inverted Data Output	
22	Rx2p	Receiver Non-Inverted Data Output	
23	GND	Ground	1
24	Rx4n	Receiver Inverted Data Output	
25	Rx4p	Receiver Non-Inverted Data Output	
26	GND	Ground	1
27	ModPrSL	Module Present	
28	IntL	Interrupt	
29	VccTx	+3.3V Power supply transmitter	

30	Vcc1	+3.3V Power Supply	
31	LPMODE	Low Power Mode	
32	GND	Ground	1
33	Tx3p	Transmitter Non-Inverted Data Input	
34	Tx3n	Transmitter Inverted Data Input	
35	GND	Ground	1
36	Tx1p	Transmitter Non-Inverted Data Input	
37	Tx1n	Transmitter Inverted Data Input	
38	GND	Ground	1

**Notes:**

1.GND is the symbol for signal and supply (power) common for the QSFP28 module. All are common within the module and all module voltages are referenced to this potential unless otherwise noted. Connect these directly to the host board signal common ground plane. Circuit ground is internally isolated from chassis ground.

## 8. Typical Application Circuit

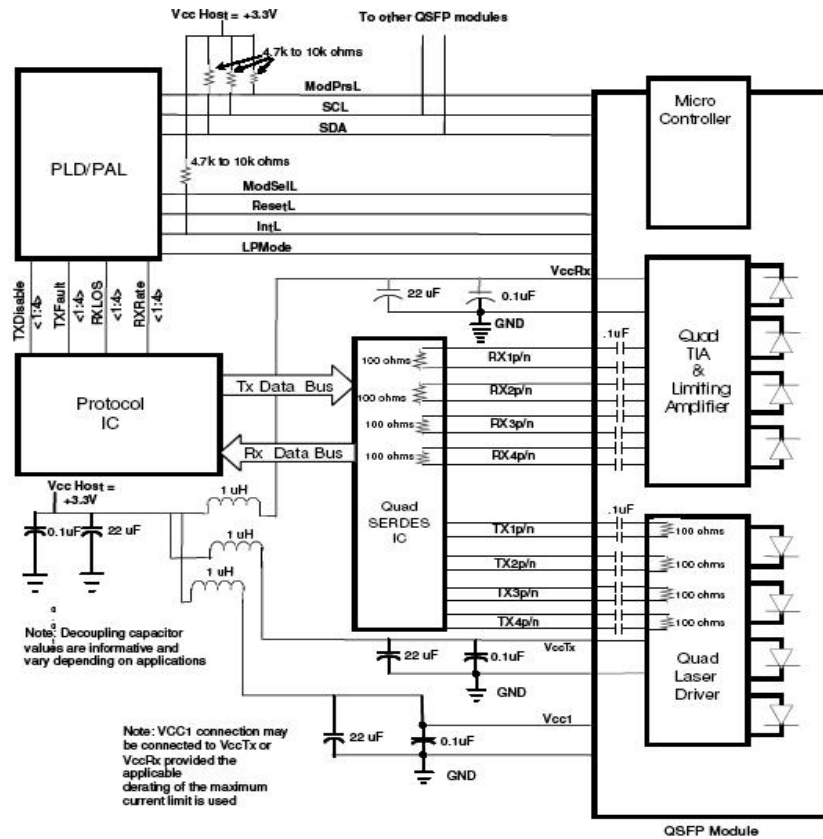

Figure 3 Typical application circuit

## 9. Package Dimensions

Figure 4 shows the package dimensions of the module. The module is designed to be compliant with QSFP28 MSA specification. Package dimensions are specified in SFF-8665.

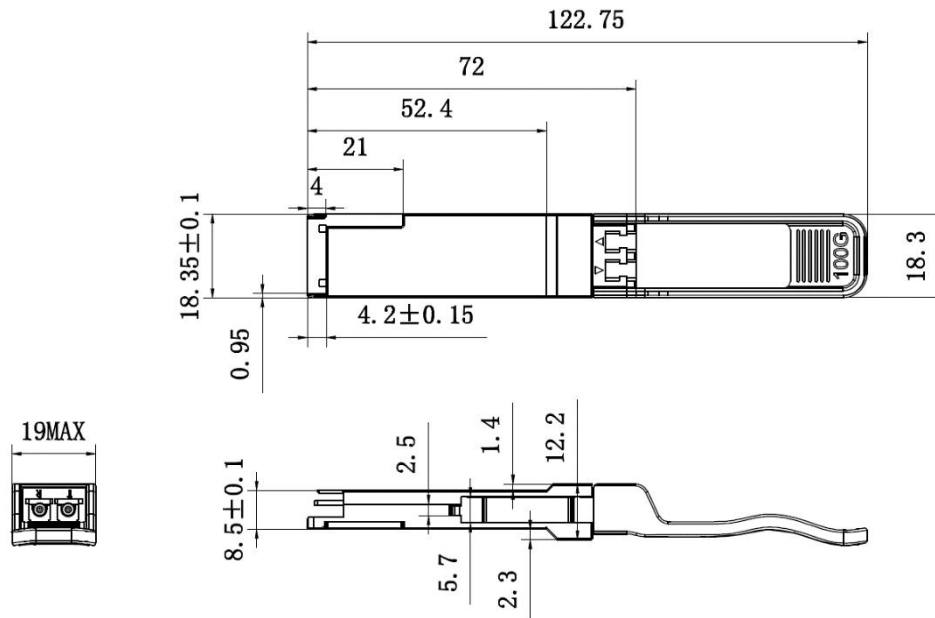

Figure 4 Package Dimensions

## 10. For More Information

Hirundo Optics Inc

2nd floor, building-6, #16 Xinfu Road South Cable industrial park Rongli Ronggui street  
Shunde district Foshan City, Guangdong province, China;

Zip Code: 528300

Tel. 0757-26619220

<http://www.hirundo-link.com/>