

100G QSFP28 2km PSM4 Transceiver Specification

HTQ28-3104-02BD

Feature

- ◆ Hot-pluggable QSFP28 form factor
- ◆ Supports 103.1 Gb/s aggregate bit rate
- ◆ Power dissipation < 3.5W
- ◆ RoHS-6 compliant
- ◆ Single 3.3V power supply
- ◆ Up to 2km of Single Mode Fiber (SMF)
- ◆ 4x25G retimed electrical interface
- ◆ Parallel MPO receptacle
- ◆ I2C management interface
- ◆ 0°C to +70°C case operating temperature

Applications

- ◆ 100G PSM4 applications with FEC
- ◆ Datacenter and enterprise networking

Standards

- ◆ QSFP MSA
- ◆ SFF-8636

Description

Hirundo's 100G QSFP28 PSM4 is a parallel 100 Gbps single mode optical transceiver designed for optical communication applications. This product provides increased port density, offering four independent transmit and receive channels. Each channel operates at 25Gbps, resulting in an aggregate data rate of 100Gbps on 2km of single mode fiber. An optical fiber ribbon cable with an MTP/MPO connector can be plugged into the QSFP28 module receptacle. The guide pins inside the receptacle ensure proper alignment. The product is designed with form factor, optical/electrical connection and digital diagnostic interface according to the QSFP28 Multi-Source Agreement (MSA). It has been designed to meet the harshest external operating conditions including temperature, humidity and EMI interference. The module can be managed through the I2C two-wire serial interface.

1. Ordering Information

Table 1.1 Ordering Information

Part No.	Specifications							
	Package	Date rate (Gbps)	Wavelength (nm)	Optical Power (dBm)	Sensitivity OMA(dBm)	Temp (°C)	Reach (km)	Connector
HTQ28-3104-02BD	QSFP28	4*25.78	1310	-6~2dBm	<-10.5	0~70	2	MPO
PN	HTQ28-3104-02BD							
Description	4X25Gbps,SMF, 2km, 0-70°C							
SAP No	-							
Customer PN	-							

2. Revision History

Table 2.1 Revision History

Version	Initiated	Reviewed	Revision	Date
V1.0	Leo	Virgil	LiuSJ	2020.12.30

3. Absolute Maximum Ratings and Recommended Operating Conditions

Table 3.1 Absolute Maximum Ratings

Parameter	Symbol	Unit	Min	Max
Storage Temperature Range	Ts	°C	-40	+85
Relative Humidity	RH	%	5	85
Power Supply Voltage	Vcc	V	-0.5	+4.0
Signal Input Voltage		V	-0.3	Vcc+0.3
Receiver Damage Threshold		dBm	+3.5	

Table 3.2 Recommended Operating Conditions

Parameter	Symbol	Unit	Min	Typ	Max
Operating Case Temperature	Tc	°C	0		70
Power Supply Voltage	Vcc	V	3.135	3.3	3.465
Bit Rate(Per channel)	BR	Gbps		25.78	
Bit Error Ratio	BER				5X10 ⁻⁵
Max Supported Link Length	L	Km			2

4. Optical Specification

Table 4.1 Optical Specifications

Parameter	Symbol	Unit	Min	Typ	Max	Notes
Transmitter (per Lane)						
Signaling rate per lane		Gbps		25.78125		
Center wavelength	λ_c	nm	1295	1310	1325	
Spectral Width(-20dB)	SW	nm			1	
Transmit OMA per Lane	TxOMA	dBm	-5.0		2.2	
Average Launch Power per Lane	TXPx	dBm	-6.0		2.0	
Optical Extinction Ratio	ER	dB	3.5			
Transmitter and Dispersion Penalty per lane	TDP	dB			3	
Side-Mode Suppression Ratio	SMSR	dB	30			
Relative Intensity Noise	RIN	dB/Hz			-128	
Optical Return Loss Tolerance		dB			20	
Transmitter Reflectance		dB			-12	
Average launch power of OFF Transmitter, each lane		dBm			-30	
Transmitter Eye mask definition {X1,X2,X3, Y1,Y2,Y3}			{0.31,0.4,0.45,0.34,0.38,0.4}			Hit ratio 5×10^{-5}
Receiver(per Lane)						
Signaling rate per lane		Gbps		25.78125		
Center wavelength	λ_{IN}	nm	1295	1310	1325	
Damage Threshold Per Lane	DT	dBm	3.5			
Average receive Power per Lane	RXPx	dBm	-		2.5	
RX Sensitivity (OMA) per Lane	R _{sens}	dBm	-		-10.5	5×10^{-5} BER
Receiver reflectance	R _{fl}	dB			-26	
LOS De-Assert	LOSD	dBm			-12	
LOS Assert	LOSA	dBm	-18			
LOS Hysteresis		dB	0.5	1.5	5	

5. Electrical Specification

Table 5.1 Electrical Specifications

Parameter	Symbol	Unit	Min	Typ	Max	Notes
Supply Voltage	VCC	V	3.135	3.3	3.465	
Supply Current	ICC	A		1.06		
Power Consumption	Pc	W			3.5	
Transmitter						
Signaling rate per lane		Gbps		25.7812		
Input Differential Impedance	R _{IN}	Ω	90	100	110	
Differential data input swing	V _{IN}	mVp-p	180		900	
Receiver						
Signaling rate per lane		Gbps		25.7812		
Output Differential Impedance	R _{OUT}	Ω	90	100	110	
Differential data output swing	V _{OUT}	mVp-p	400		800	
IIC communication						
IIC Clock frequency	-	KHz	100		400	

6. Module Memory Map

The common memory map for managed external cable interfaces is utilized for serial ID, digital monitoring and control functions. The map is arranged into a single lower page address space of 128 bytes and multiple upper address pages.

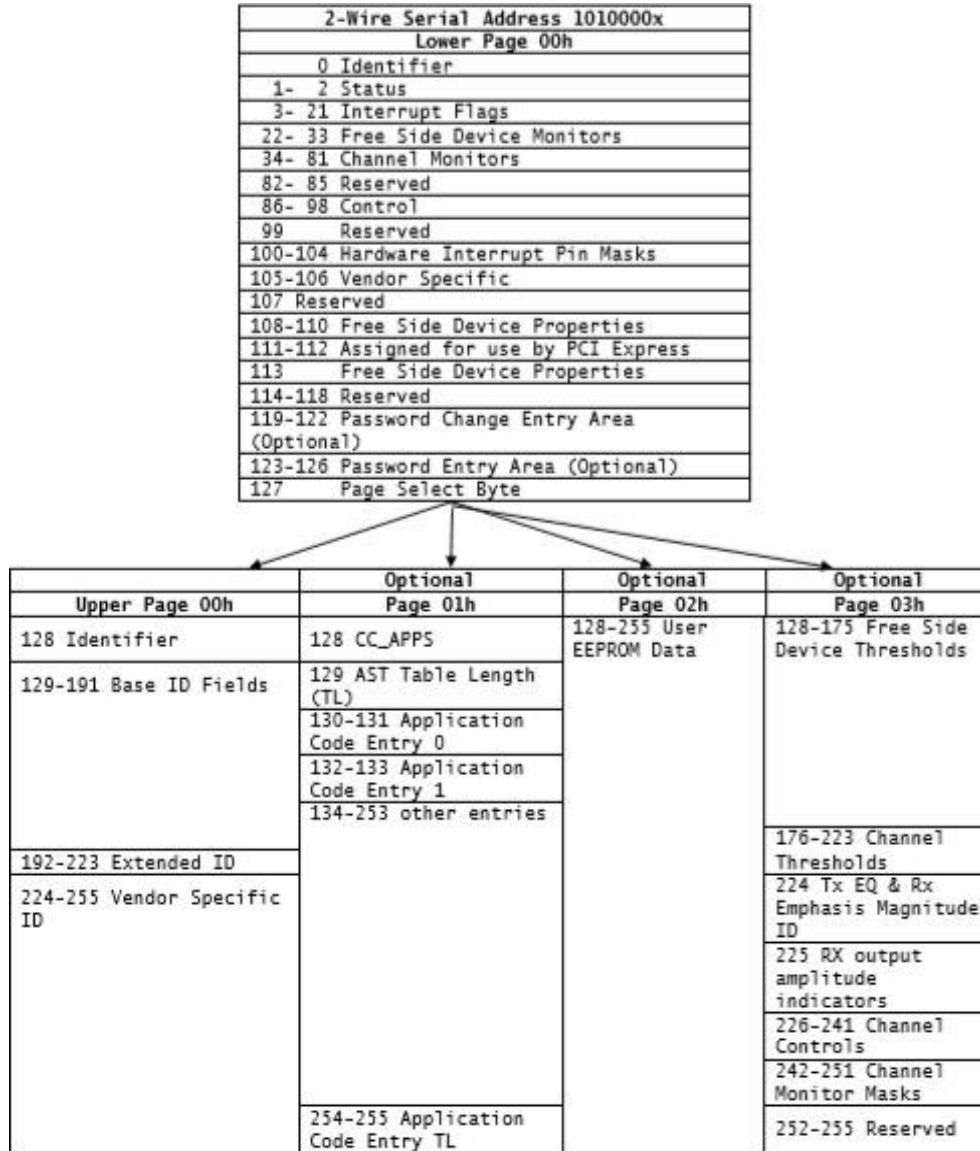

Figure 1 Digital Diagnostic Memory Map

7. Pin Assignment and Pin Description

7.1 Pin Assignment

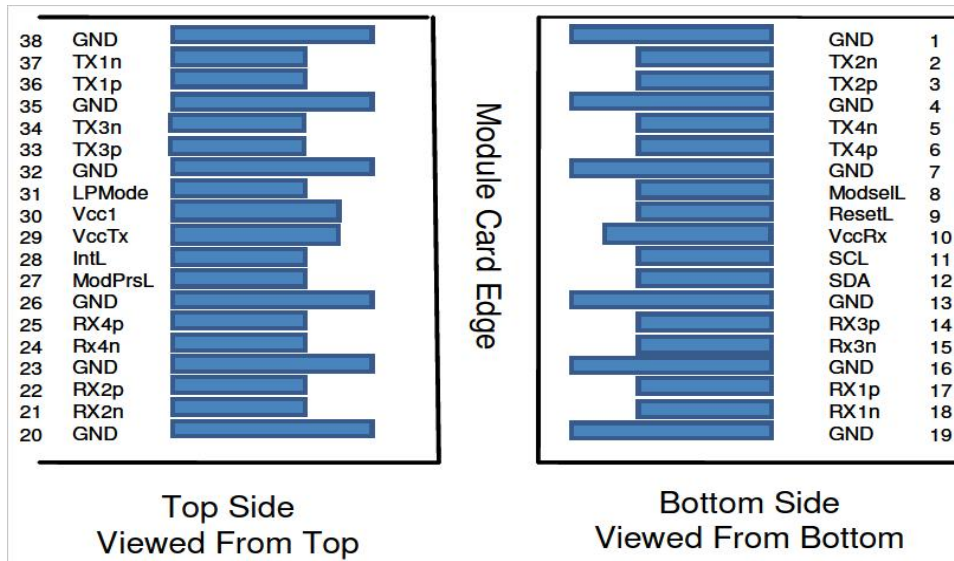

Figure 2 Electrical Pin-out Details

7.2 Pin Description

Table 7.1 Pin Description

Pin	Symbol	Name/Description	Note
1	GND	Ground	1
2	Tx2n	Transmitter Inverted Data Input	
3	Tx2p	Transmitter Non-Inverted Data Input	
4	GND	Ground	1
5	Tx4n	Transmitter Inverted Data Input	
6	Tx4p	Transmitter Non-Inverted Data Input	
7	GND	Ground	1
8	ModSe1L	Module Select	
9	ResetL	Module Reset	
10	Vcc Rx	+3.3V Power supply receiver	
11	SCL	2-wire serial interface clock	
12	SDA	2-wire serial interface data	
13	GND	Ground	1
14	Rx3p	Receiver Non-Inverted Data Output	
15	Rx3n	Receiver Inverted Data Output	
16	GND	Ground	1
17	Rx1p	Receiver Non-Inverted Data Output	
18	Rx1n	Receiver Inverted Data Output	
19	GND	Ground	1
20	GND	Ground	1
21	Rx2n	Receiver Inverted Data Output	
22	Rx2p	Receiver Non-Inverted Data Output	
23	GND	Ground	1
24	Rx4n	Receiver Inverted Data Output	
25	Rx4p	Receiver Non-Inverted Data Output	
26	GND	Ground	1
27	ModPrSL	Module Present	
28	IntL	Interrupt	
29	VccTx	+3.3V Power supply transmitter	
30	Vcc1	+3.3V Power Supply	

31	LPMODE	Low Power Mode	
32	GND	Ground	1
33	Tx3p	Transmitter Non-Inverted Data Input	
34	Tx3n	Transmitter Inverted Data Input	
35	GND	Ground	1
36	Tx1p	Transmitter Non-Inverted Data Input	
37	Tx1n	Transmitter Inverted Data Input	
38	GND	Ground	1

Notes:

1. GND is the symbol for signal and supply (power) common for the QSFP28 module. All are common within the module and all module voltages are referenced to this potential unless otherwise noted. Connect these directly to the host board signal common ground plane. Circuit ground is internally isolated from chassis ground.

8. Typical Application Circuit

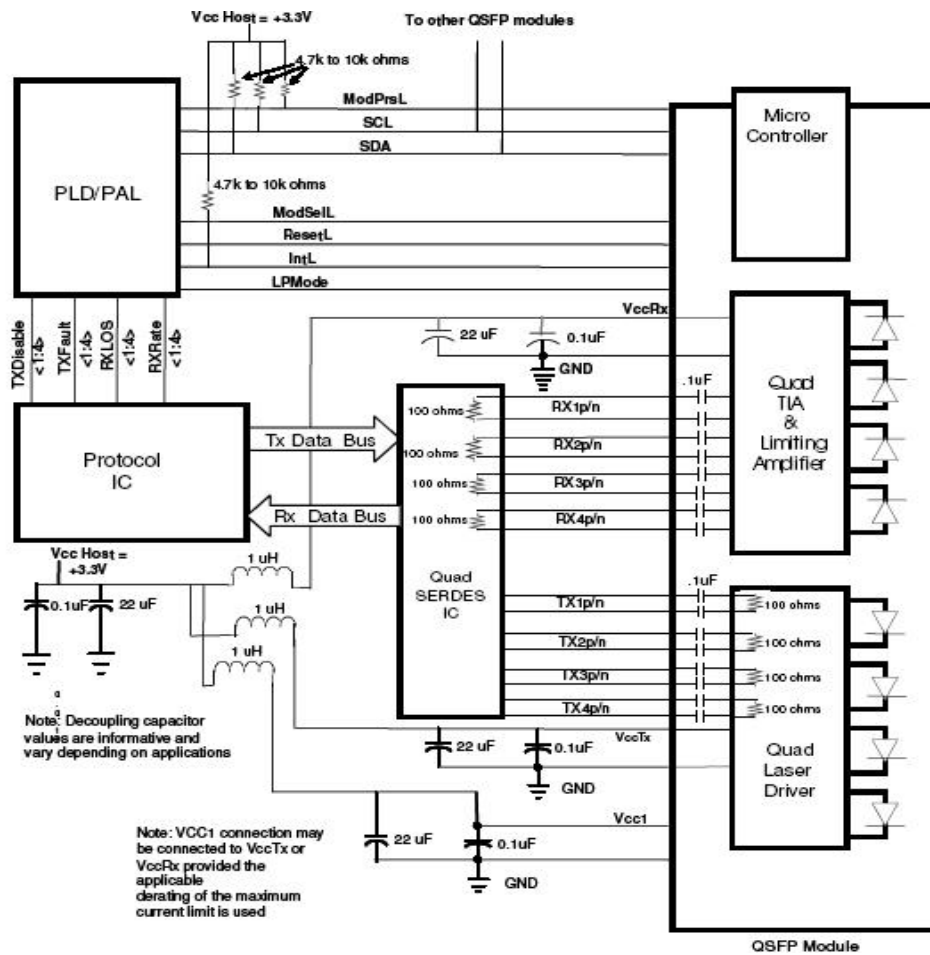

Figure 3 Typical application circuit

9. Package Dimensions

Figure 4 shows the package dimensions of the module. The module is designed to be compliant with QSFP MSA specification.

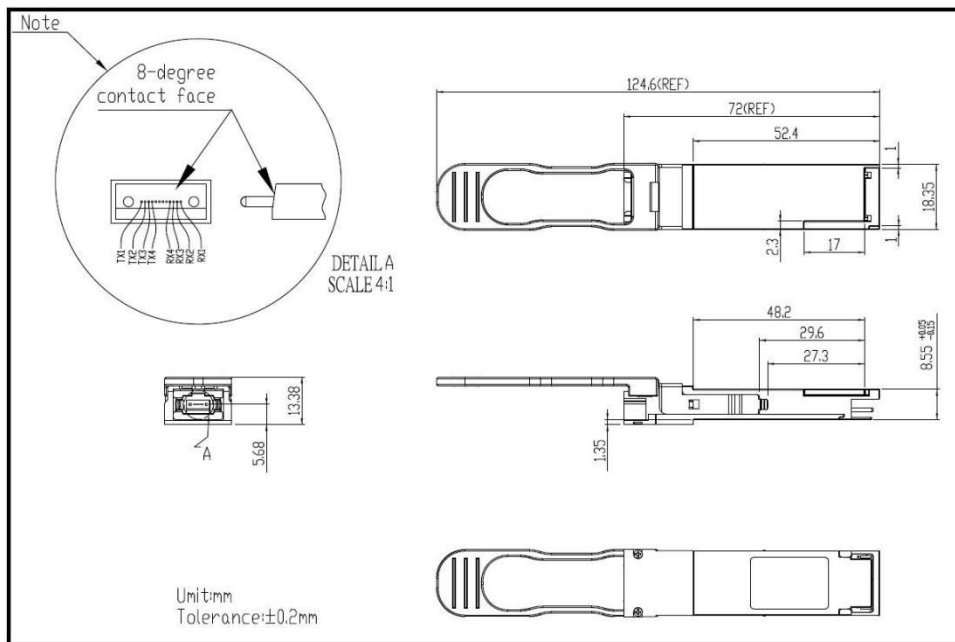

Figure 4 Package Dimensions

10. For More Information

Hirundo Optics Inc

2nd floor, building-6, #16 Xinfa Road South Cable industrial park Rongli Ronggui street
Shunde district Foshan City, Guandong province, China;

Zip Code: 528300

Tel. 0757-26619220

<http://www.hirundo-link.com/>