

100G QSFP28 100m SR4 Transceiver Specification

HTQ28-8508-M1BD

Feature

- ◆ Up to 70m transmission on MMF OM3 and 100m transmission on MMF OM4
- ◆ Supports 103.1Gbps aggregate bit rate
- ◆ 4x25Gbps electrical interface
- ◆ Hot pluggable QSFP28 footprint
- ◆ Single 3.3V power supply
- ◆ Maximum power dissipation<2W
- ◆ RoHS-6 compliant and lead-free
- ◆ I2C management interface
- ◆ DDM function implemented
- ◆ 0°C to +70°C case operating temperature

Applications

- ◆ 100GBASE-SR4 100G Ethernet links
- ◆ Other high speed data connections

Standards

- ◆ QSFP28 MSA
- ◆ IEEE802.3bm 100GBASE-SR4
- ◆ ROHS Compliant

Description

The Hirundo ' s HTQ28-8508-M1BD transceiver is designed for 100Gigabit Ethernet over Multi-Mode fiber with 70m using OM3 fiber or 100m using OM4 fiber.They are compliant with SFF-8665, SFF-8636 and IEEE 802.3bm standard. Digital diagnostics functions are available via an I2C interface, as specified by the QSFP28 MSA.

1. Ordering Information

Table 1.1 Ordering Information

Part No.	Specifications							
	Package	Date rate (Gbps)	Wavelength (nm)	Optical Power (dBm)	Sensitivity (dBm)	Temp (°C)	Reach (m)	Connector
HTQ28-8508-M1BD	QSFP28	103.1	850	-6~2.4	<-10.3	0~70	100	MPO
PN	HTQ28-8508-M1BD							
Description	100Gbps,MMF,100m,0-70°C							
SAP No	-							
Customer PN	-							

2. Revision History

Table 2.1 Revision History

Version	Initiated	Reviewed	Revision	Date
V1.0	Leo	Virgil	LiuSJ	2020.12.30

3. Absolute Maximum Ratings and Recommended Operating Conditions

Table 3.1 Absolute Maximum Ratings

Parameter	Symbol	Unit	Min	Max
Storage Temperature Range	Ts	°C	-40	+85
Relative Humidity	RH	%	5	95
Power Supply Voltage	Vcc	V	-0.5	4.0
Signal Input Voltage		V	-0.3	Vcc+0.3
Receiver Damage Threshold		dBm	+3.4	

Table 3.2 Recommended Operating Conditions

Parameter	Symbol	Unit	Min	Typ	Max
Operating Case Temperature	Tc	°C	0		70
Power Supply Voltage	Vcc	V	3.135	3.3	3.465
Bit Rate(Per channel)	BR	Gbps		25.78	
Bit Error Ratio	BER				5*10 ⁻⁵
Max Supported Link Length(OM3 MMF)	L	m			70
Max Supported Link Length(OM4 MMF)	L	m			100

4. Optical Specification

Table 4.1 Optical Specifications

Parameter	Symbol	Unit	Min	Typ	Max	Notes
Transmitter (per Lane)						
Signaling rate per lane		Gbps		25.78		
Center wavelength	λ_c	nm	840		860	
RMS Spectral Width	SW	nm			0.6	
Transmit OMA per Lane	TxOMA	dBm	-4		3	
Average Launch Power per Lane	TXPx	dBm	-6		2.4	
Optical Extinction Ratio	ER	dB	2			
Relative Intensity Noise	RIN	dB/Hz			-128	
Optical Return Loss Tolerance		dB			12	
Average launch power of OFF Transmitter, each lane		dBm			-30	
Transmitter Eye mask definition {X1,X2,X3, Y1,Y2,Y3}			Compliant with IEEE 802.3bm			Hit ratio 5×10^{-5}
Receiver(per Lane)						
Signaling rate per lane		Gbps		25.78		
Center wavelength	λ_{IN}	nm	840		860	
Average power each lane	RXPx	dBm	-10.3		2.4	
Rx Sensitivity per lane	R _{SENS}	dBm			-10.3	Note1
Receiver reflectance	R _{fl}	dB			-12	
LOS De-Assert	LOSD	dBm			-13	
LOS Assert	LOSA	dBm	-30			
LOS Hysteresis		dB	0.5		6	

Note1: Measured with a PRBS 2³¹-1 test pattern, @25.78Gb/s, BER<5*5⁻⁵.

5. Electrical Specification

Table 5.1 Electrical Specifications

Parameter	Symbol	Unit	Min	Typ	Max	Notes
Supply Voltage	VCC	V	3.15	3.3	3.45	
Supply Current	ICC	A		0.6		
Power Consumption	Pc	W			2	
Transmitter						
Signaling rate per lane		Gbps		25.78		
Input Differential Impedance	R _{IN}	Ω	90	100	110	
Differential data input swing	V _{IN}	mVp-p	180		1000	
Receiver						
Signaling rate per lane		Gbps		25.78		
Output Differential Impedance	R _{OUT}	Ω	90	100	110	
Differential data output swing	V _{OUT}	mVp-p	300		900	
IIC communication						
IIC Clock frequency	-	KHz	100		400	

6. Module Memory Map

The common memory map for managed external cable interfaces is utilized for serial ID, digital monitoring and control functions. The map is arranged into a single lower page address space of 128 bytes and multiple upper address pages.

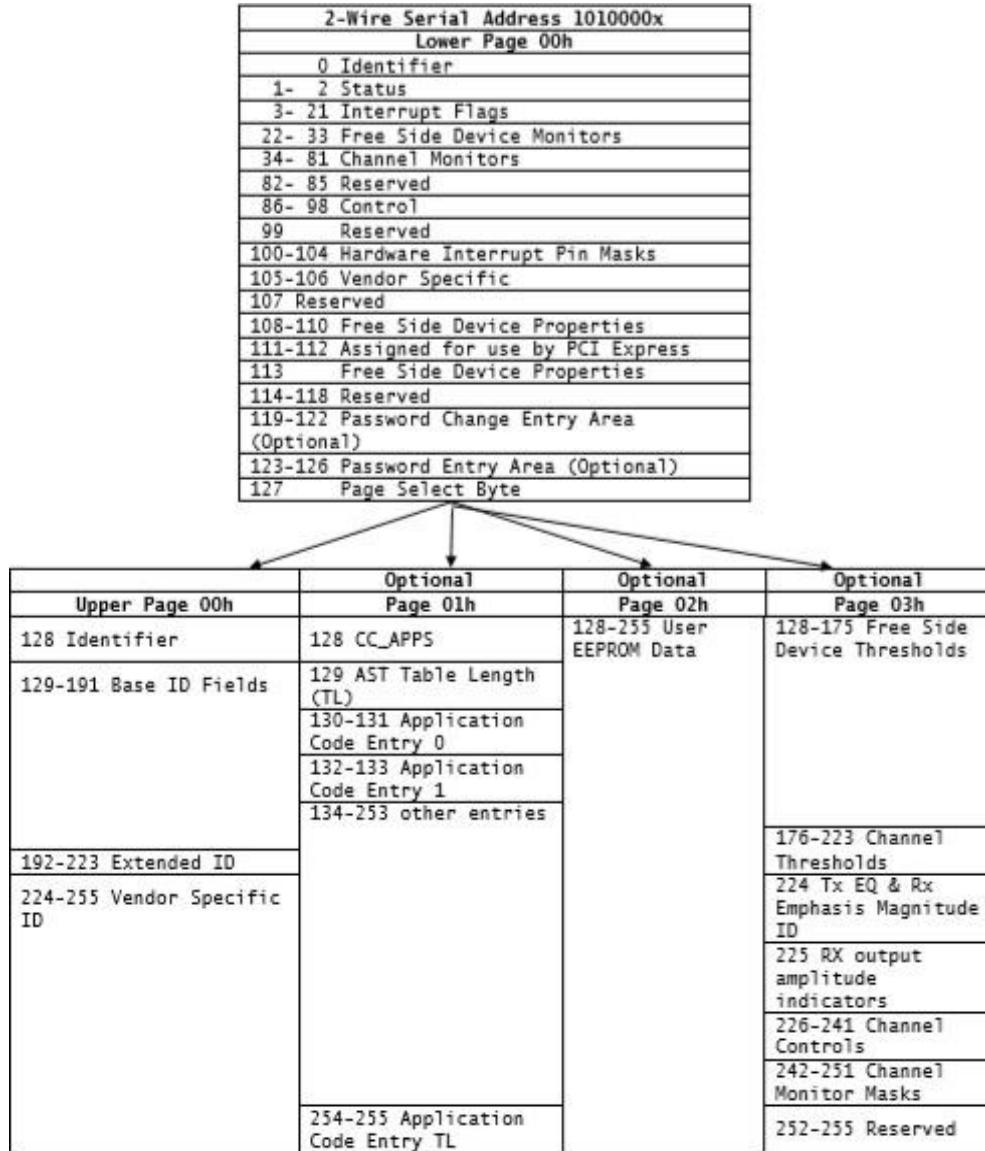

Figure 1 Digital Diagnostic Memory Map

7. Pin Assignment and Pin Description

7.1 Pin Assignment

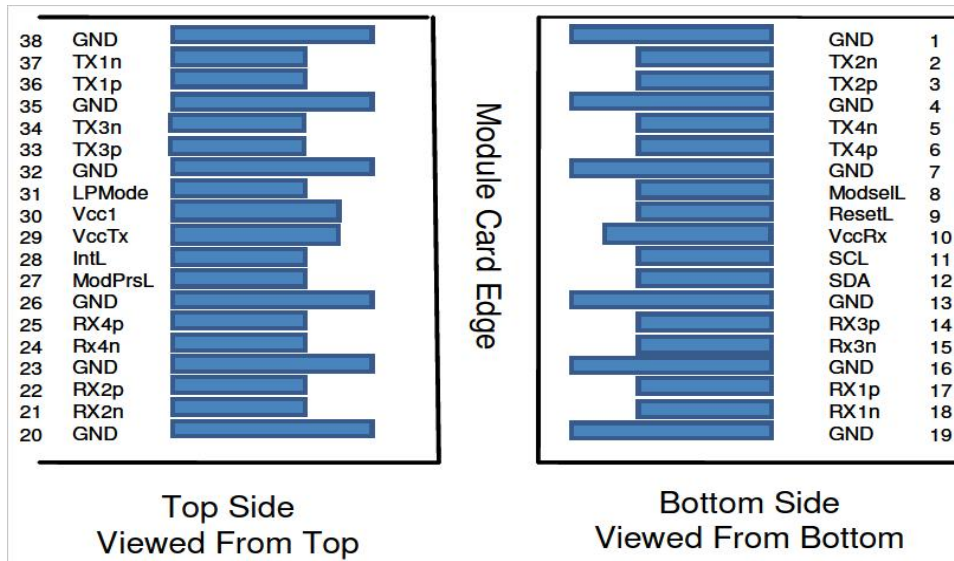

Figure 2 Electrical Pin-out Details

7.2 Pin Description

Table 7.1 Pin Description

Pin	Symbol	Name/Description	Note
1	GND	Ground	1
2	Tx2n	Transmitter Inverted Data Input	
3	Tx2p	Transmitter Non-Inverted Data Input	
4	GND	Ground	1
5	Tx4n	Transmitter Inverted Data Input	
6	Tx4p	Transmitter Non-Inverted Data Input	
7	GND	Ground	1
8	ModSe1L	Module Select	
9	ResetL	Module Reset	
10	Vcc Rx	+3.3V Power supply receiver	
11	SCL	2-wire serial interface clock	
12	SDA	2-wire serial interface data	
13	GND	Ground	1
14	Rx3p	Receiver Non-Inverted Data Output	
15	Rx3n	Receiver Inverted Data Output	
16	GND	Ground	1
17	Rx1p	Receiver Non-Inverted Data Output	
18	Rx1n	Receiver Inverted Data Output	
19	GND	Ground	1
20	GND	Ground	1
21	Rx2n	Receiver Inverted Data Output	
22	Rx2p	Receiver Non-Inverted Data Output	
23	GND	Ground	1
24	Rx4n	Receiver Inverted Data Output	
25	Rx4p	Receiver Non-Inverted Data Output	
26	GND	Ground	1
27	ModPrSL	Module Present	
28	IntL	Interrupt	
29	VccTx	+3.3V Power supply transmitter	
30	Vcc1	+3.3V Power Supply	

31	LPMODE	Low Power Mode	
32	GND	Ground	1
33	Tx3p	Transmitter Non-Inverted Data Input	
34	Tx3n	Transmitter Inverted Data Input	
35	GND	Ground	1
36	Tx1p	Transmitter Non-Inverted Data Input	
37	Tx1n	Transmitter Inverted Data Input	
38	GND	Ground	1

Notes:

1. GND is the symbol for signal and supply (power) common for the QSFP+ module. All are common within the module and all module voltages are referenced to this potential unless otherwise noted. Connect these directly to the host board signal common ground plane. Circuit ground is internally isolated from chassis ground.

8. Typical Application Circuit

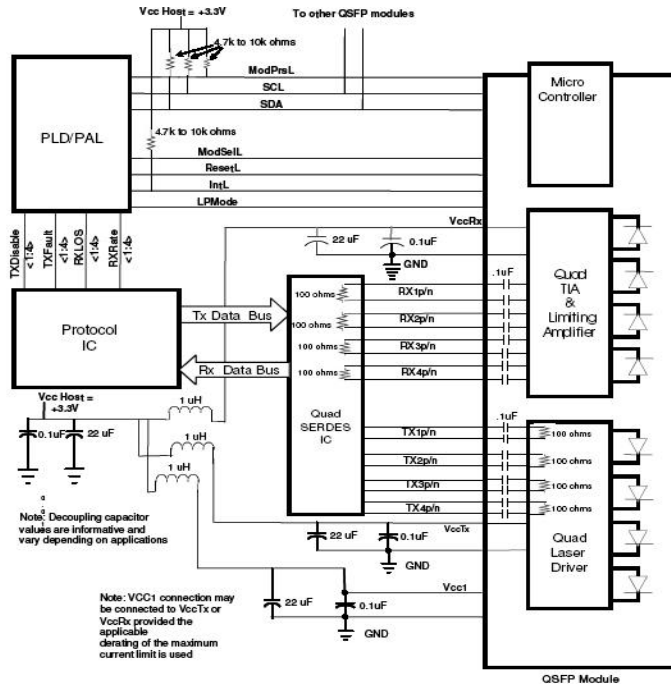

Figure 3 Typical application circuit

9. Package Dimensions

Figure 4 shows the package dimensions of the module. The module is designed to be compliant with QSFP+ MSA specification.

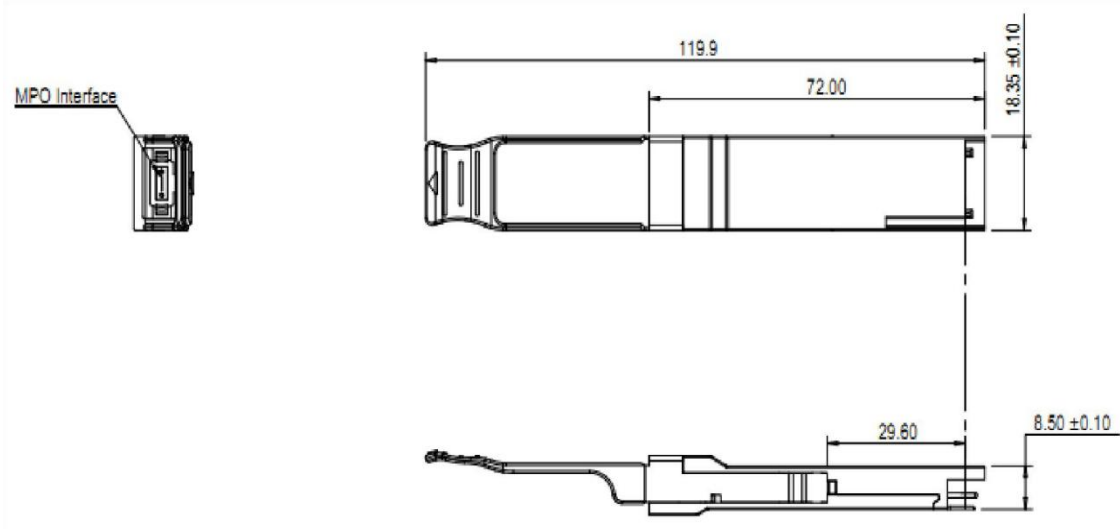

Figure 4 Package Dimensions

10. For More Information

Hirundo Optics Inc

2nd floor, building-6, #16 Xinfu Road South Cable industrial park Rongli Ronggui street
Shunde district Foshan City, Guangdong province, China;

Zip Code: 528300

Tel. 0757-26619220

<http://www.hirundo-link.com/>