

1.Product Information

PN	Description
SLED-1513101114-01	SLED chip, wavelength 1310nm, power ≥15mW, 14-pin butterfly package built-in optical isolator and thermoelectric cooler 1.0±0.1m optical fiber pigtail with 900um loose tube,FC/APC connector.

2.REFERENCE DOCUMENT

- Visual Inspection Criteria SLED Chip on Submount Procedure
- MIL STD 883 C method.
- Bellcore GR-468-CORE.

3.Electro-Optical Performance (TSLED = 20°C)

Parameter	Symbol	Cond.	Min	Typ	Max	Unit
Operating Current	I_{op}				600	mA
Power in SMF	P_o	$I_{op,max}$	15	20		mW
Center Wavelength	λ_c	$I_{op,max}$	1290	1310	1330	nm
Bandwidth FWHM		$I_{op,max}$	60	90		nm
Spectral ripple[RB=0.1nm]		$I_{op,max}$		0.1	0.3	dB
Monitor PD Current	I_{MPD}	$I_{op,max}$	100			μA
Monitor PD bias voltage			0		-12	V

*Measurement conditions:

- $I_{op}=I_{op, Max}$

- Monitor PD bias voltage:0 Volts

Input resistance of the Monitor PD current measurement circuit 100Ω

4.Absolute Maximum Ratings

Stresses beyond the absolute maximum ratings may cause permanent damage to the device. Exposure to absolute maximum rating conditions for extended periods may affect device reliability.

Parameters	Symbol	Cond.	Min	Max	Unit
Forward current	I_F			650	mA
Reverse voltage	V_R			-2	V
Forward voltage	V_F	$I_{F,max}$		2	V
Storage temperature	T_{stg}		-40	85	°C
Operating temperature	T_{op}	$I_{F,max}$	-20	65	°C
Storage humidity		<30°C >30°C	5	95 85	%RH
Thermoelectric cooler voltage	V_{tec}	**		4.0	V
Thermoelectric cooler current	I_{tec}	**		1.8	A
Thermistor Resistance	R_{th}	20°C		12.5	kΩ
Thermistor constant	B			3892	K
Lead soldering Temperature				260	°C
Lead soldering duration				10	s
ESD		Human b.m		500	V

**Performance values with hot side temperatures 50°C

5.SCREENING

The produced 1300nm SLED Module is required to meet all operating conditions specified in Table 3. Electro-Optical Performance Specifications after being subjected to the following screening tests.

Test Item	Test Conditions	Reference
Seal	Fine:Condition A1 Gross:Condition C	MIL-STD-883,Method 1014 Temperature max 85°C
Temperature Cycling	-40°C to +85°C Ramp rate>=5°C/min 10 cycles	MIL-STD-883,Method 1010

6.Package Dimensions(unit:mm)

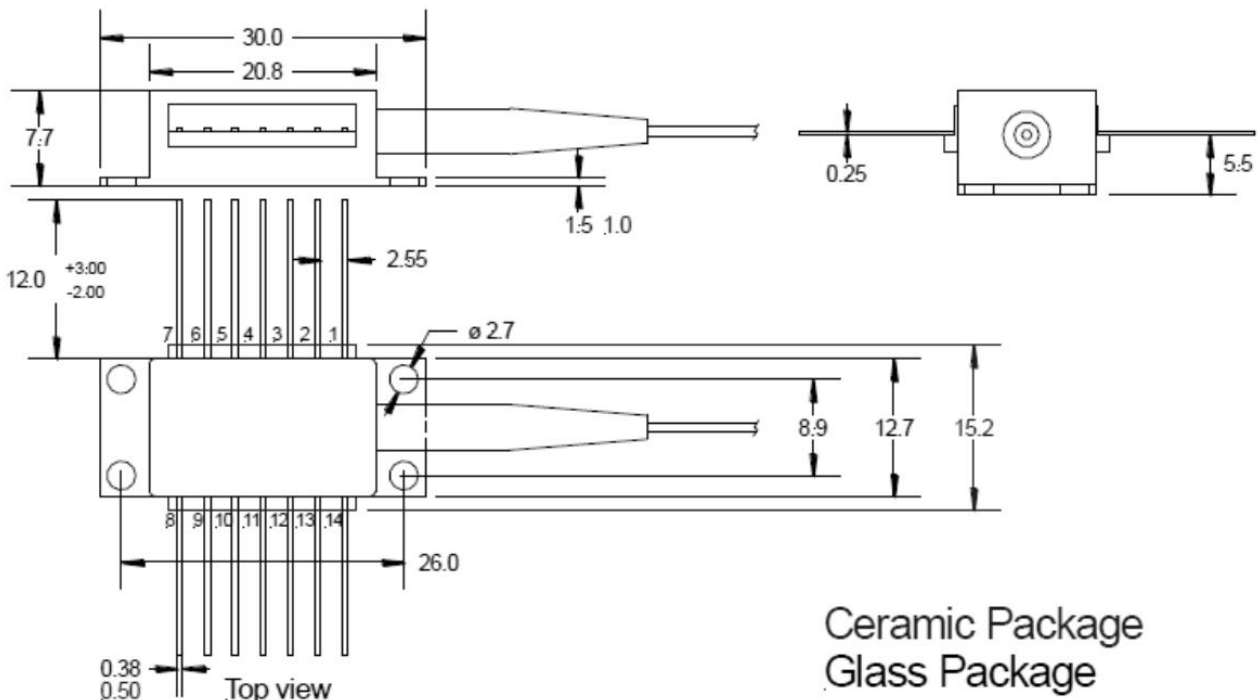

Pin	Function	Pin	Function
1	TEC(+)	8	NC
2	Thermistor	9	NC
3	Monitor Diode Anode	10	SLED Anode(+)
4	Monitor Diode Cathode	11	SLED Cathode(-)
5	Thermistor	12	NC
6	NC	13	Case Ground
7	NC	14	TEC(-)

7.Fiber and connector

Part	Description
SM Fiber	SMF-28,9/125 μ m
Loose tube secondary coating	900 μ m
Fiber pigtail length(min)	1m
Optical connector	FC/APC Narrow Key(2.0mm)

8. Test Report

Test report will be attached with each product. The following characteristic test data should be included :

-Optical Output Power, Center Wavelength, P-I curve, Pin Assignments.

9. Packaging

Black vacuumize anti-static plastic package.

